



EXCLUSIVE AUTOMOTIVE PRODUCTS

**AUTOTECNICA SEAT FITTING INSTRUCTION
 TO SUIT NISSAN PATROL GQ Y60 PART NO.660NEWRL**

PLEASE READ THE INSTRUCTION IN FULL BEFORE FITTING AUTOTECNICA SEAT/SEATS TO VEHICLE

1. Park the vehicle in a suitable position and ensure the hand brake is engaged. Remove the seat from the vehicle and retain all the bolts removed. The original bolts will be re-used when fitting the new seat.

Separate the original seat sliders from the seat and retain the bolts removed, some will be used in fitting the new seat.

Photo (A)



(Original seat sliders removed from vehicle)

Photo (B)

Contents Included:

- 2 x 20mm Spacers
- 4 x 12mm Spacers
- 2 x 10mm Spacers
- 8 x Washers
- 6 x Spring Washers
- 2 x 20mm Bolts
- 2 x Nuts
- 4 x 43mm Bolts
- 2 x 57mm Bolts



2. ****Please note**** the installation guide below is for the driver side. Please view the image "Photo (C)" below on how the seat mounting holes should look on the adaptor once mounted to the slider. Installation for the passenger side is similar, although the bars will need to be flipped to the right-hand side.

Photo (C)

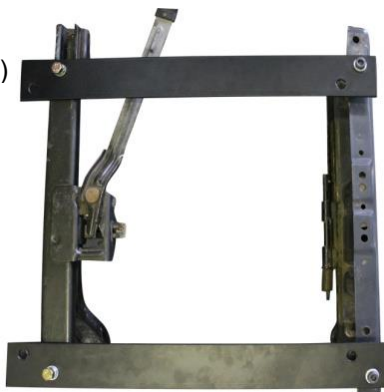

Fitting Diagram

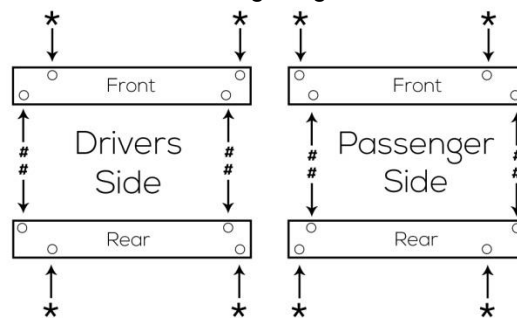

* = Slider bolt holes
 # = Seat bolt holes

3. Due to different floor pans across the GQ range, you will need to follow the following procedures.

Rest the assembled slider/ adaptors into the vehicle floor in the same position as if they were fitted in the car. By looking across from the outside frame to the inner frame, you will need to decide and choose the different spacers supplied in order to level the seat position. "Photo (D)" The spacers are to be fitted on top of the outer slider.

Photo (D)



4. If using the 20mm spaces, use the 57mm bolts and washers, secure but do not tighten the adaptor to the frame, as pictured below.

If the slider/adaptors do not require spacers, use the original bolts removed from the slider to secure the adaptors to the slider. Photo (E)''

Photo (E)

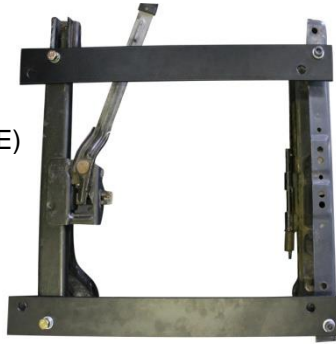

5. Place the 4 x 12mm spacers on to seat mounting holes as pictured below. "Photo (F)" Some Autotecnica seats do not need the above spacers.

Photo (F)



6. Place the sliders with the adaptors attached to the seat as pictured below, using the 4 x 43mm bolts, 4 x washers, and 4 x spring washers. Ensure to check and secure all the bolts and nuts on the slider/adaptors and seat base and tighten them securely. "Photo (G)"

Photo (G)



7. Place the seat into the vehicle floor and by using the original bolts retained tighten the seat securely into position.



Image used for illustration purposes only

Note: The Autotecnica seats are ADR and 639F adaptor is ADR Approved.

We recommend however that the seat conversion is checked by an accredited engineer after fitting the seat or seats to the vehicle